



WMTS-040:2021[a](#)

Waste pipe connection outlets and gratings, separate or integral

WaterMark Technical Specification

Document formerly known as:-

ATS 5200.040 – 2005 Technical Specification for Plumbing and Drainage Products
Waste pipe connection outlets and gratings, separate or integral.

Publication History:-

First published as ATS 5200.040—2005.
Revised and redesignated as WMTS-040:2016.
Revised as WMTS-040:2018
Revised as WMTS-040:2021
[Revised as WMTS-040:2021a](#)

2021

IMPORTANT NOTICE AND DISCLAIMER

On 25 February 2013 management and administration of the WaterMark Certification Scheme transferred to the Australian Building Codes Board (ABCB). From this date all new technical specifications will be named WaterMark Technical Specifications (WMTS). The WaterMark Schedule of Products lists all current WMTS.

This Technical Specification supersedes WaterMark Technical Specification WMTS-040:~~2018~~2021.

While the ABCB, the participating Governments and other groups or individuals who have endorsed or been involved in the development of the WMTS, have made every effort to ensure the information contained in this document is accurate and up to date, such information does in no way constitute the provision of professional advice.

The ABCB gives no warranty or guarantee and accepts no legal liability whatsoever arising from or connected to, the accuracy, reliability, currency or completeness of any material contained in this document.

Users should seek appropriate independent professional advice prior to relying on, or entering into any commitment based on material in this document in relation to plumbing or related activities. Its interpretation in no way overrides the approvals processes in any jurisdiction.

The ABCB welcomes suggestions for improvement in the WMTS, and encourage readers to notify us immediately of any apparent inaccuracies or ambiguities. Contact the ABCB via phone on 1300 134 631, email at watermark@abcb.gov.au or write to the WaterMark Administering Body, ABCB, GPO Box 2013, Canberra ACT 2601.

Copyright within the following document is owned by the Australian Government and States and Territories of Australia and its Licensors.

Apart from any use permitted under the Copyright Act 1968, no part may be reproduced without prior permission. Requests and enquires concerning reproduction and rights should be directed to:

Chief Executive Officer
Australian Building Codes Board
GPO Box 2013
Canberra ACT 2601
Phone 1300 134 631 – Fax 02 6213 7287

PREFACE

WaterMark Technical Specification WMTS-040:2021^a Waste pipe connection outlets and gratings, separate or integral was prepared by industry to supersede WaterMark Technical Specification WMTS-040:~~2018~~2021.

The objective of this Technical Specification is to enable product certification in accordance with the requirements of the Plumbing Code of Australia (PCA).

The objective of this revision is to ~~include additional materials and amend references to secondary specifications~~ amend the Stainless Steel requirements.

The word 'VOID' set against a clause indicates that the clause is not used in this Technical Specification. The inclusion of this word allows a common use clause numbering system for the WaterMark Technical Specifications.

The term 'normative' has been used in this Technical Specification to define the application of the appendices to which they apply. A 'normative' appendix is an integral part of a Technical Specification.

The test protocol and information in this Technical Specification was arranged by industry to meet the authorisation requirements given in the PCA.

The WaterMark Schedule of Products and Schedule of Excluded Products are dynamic lists and change on a regular basis. These lists are located on the ABCB website (www.abcb.gov.au). These lists are version controlled with appropriate historic references.



ACKNOWLEDGEMENTS

Australian Technical Specification ATS 5200.040 – 2005, on which this technical specification is based, was prepared by Standards Australia Committee WS-031, Technical Procedures for Plumbing and Drainage Products Certification. It was approved on behalf of the Council of Standards Australia on 20 December 2004.

The following organisations were represented on Committee WS-031 in the preparation of Australian Technical Specification ATS 5200.040 – 2005.

- AUSTAP
- Australian Electrical and Electronic Manufacturers Association
- Australian Industry Group
- CSIRO Manufacturing and Infrastructure Technology
- Certification Interests (Australia)
- Consumer Electronics Suppliers Association
- Copper Development Centre—Australia
- Gas Appliances and Services Association
- Master Plumbers Australia
- Master Plumbers and Mechanical Services Association of Australia
- Master Plumbers, Gasfitters and Drainlayers New Zealand
- National Fire Industry Association
- New Zealand Water & Waste Association
- Plastics Industry Pipe Association of Australia
- Plumbing Industry Commission
- South Australian Water Corporation
- Water Services Association of Australia

TABLE OF CONTENTS

1	Scope	5
2	Application	6
3	Referenced documents	6
4	Definitions	7
5	Materials	7
6	Marking	8
7	Packaging	8
8	Design	8
9	Performance requirements and test methods.....	<u>1244</u>
10	Performance test sequence	12
11	Product documentation.....	12
Appendix A	Means for demonstrating compliance with this Technical Specification ...	14

DRAFT

1 SCOPE

This Technical Specification sets out requirements for metallic and plastics bodied waste pipe outlets and gratings, separate or integral, for sanitary plumbing applications.

2 APPLICATION

This Technical Specification will be referenced on the WaterMark Certification Scheme Schedule of Products.

Appendix A sets out the means by which compliance with this Technical Specification shall be demonstrated by a manufacturer for the purpose of product certification.

3 REFERENCED DOCUMENTS

The following documents are referred to in this Technical Specification:

AS

- 1589 Copper and copper alloy waste fittings
- 1650 Hot-dipped galvanized coatings on ferrous articles
- 1830 Grey cast iron
- 1874 Aluminium and aluminium alloys – Ingots and castings
- 2887 Plastic waste fittings
- 2888.1 Methods of testing plastics waste fittings Part 1: Method of determining the suitability of connection threads of BSP form
- 2888.6 Methods of testing plastics waste fittings Part 6: Method for load testing of plastics waste outlets
- 2888.7 Methods of testing plastics waste fittings Part 7: Method for testing the seal of plastics waste outlets
- 2888.8 Methods of testing plastics waste fittings Part 8: Thermal cycling test

AS/NZS

- 1260 PVC-U pipes and fittings for drain, waste and vent application
- 1734 Aluminium and aluminium alloys – Flat sheet, coiled sheet and plate
- 1866 Aluminium and aluminium alloys - Extruded rod, bar, solid and hollow shapes
- 3500.0 Plumbing and Drainage Part 0: Glossary of terms
- 3500.2 Plumbing and Drainage Part 2: Sanitary plumbing and drainage

ASTM

A240/A240M Standard specification chromium and chromium-nickel stainless steel plate, sheet and strip for pressure vessels and for general applications

BS EN

274-2 Waste fittings for sanitary purposes Part 2: Test methods

1490 Aluminium and aluminium alloy ingots and castings for general engineering purposes

EN

1253-1 Gullies for buildings – Part 1 : Trapped floor gullies with a depth water seal of at least 50mm

4 DEFINITIONS

For the purpose of this Technical Specification, the definitions given in AS/NZS 3500.0, AS 2887 and AS 1589 apply.

5 MATERIALS

5.1 Materials

The materials utilised in the manufacture of the waste pipe connection outlets, drain bodies (or channels) and gratings, separate or integral shall comply with the following requirements.

5.1.1 Plastics

Plastics components shall comply with the following requirements:

- (a) Unplasticised PVC (PVC-U) in accordance with AS/NZS 1260.
- (b) Other plastics materials such as ABS, ASA and PP able to form a fitting capable of complying with the requirements of AS 2887.

5.1.2 Metallic

Metallic components shall comply with the following requirements:

- (a) Stainless Steel, 300 series, not less than grade 304 (stainless steel shall contain not less than 8% nickel).
- (b) Sheet stainless steel, not less than grade 304 (sheet stainless steel shall contain not less than 8% nickel), ~~1.2mm thick~~, in accordance with ASTM A240/A240M.
- (c) Copper and copper alloy in accordance with AS 1589.

- (d) Grey cast iron in accordance with AS 1830.
- (e) Ductile iron in accordance with AS 1831.
- (f) Galvanised Steel in accordance with AS 1650 and limitations noted in AS/NZS 3500.2.
- (g) Aluminium shall be a corrosion resistant grade and comply with the requirements of:
 - a) AS 1874 or BS 1490 for ingots and castings; or
 - b) AS/NZS 1734 for flat sheet, coiled sheet and plate; or
 - c) AS 1866 for extruded rod, bar, solid and hollow shape.

NOTE 1: Aluminium should not be used where intended to be in direct contact with concrete/cement.

NOTE 2: Where Aluminium is used as a grating surround, waste body or tile insert grating instructions should detail the methods of installation to prevent direct contact with concrete/cement.

- (h) Where dissimilar metals are used they shall be compatible with each other.

NOTE: Dissimilar metals may present adverse chemical or galvanic reaction resulting in corrosion.

6 MARKING

Markings to be placed on products or packaging shall be in accordance with the [Manual for the WaterMark Certification Scheme](#).

In addition each waste pipe connection outlet or grating shall, as a minimum, be marked with the manufacturer's name, brand or trademark.

7 PACKAGING

Products shall be packaged in such a manner so as to avoid damage during transportation and handling.

8 DESIGN

8.1 General

The dimensions/profile, including wall thickness, shall comply with relevant or corresponding Australian Standard(s) where applicable.

8.2 Designation of size

Where the grating and outlet ends are the same size, the nominal size of the waste shall be designated by the outlet end, e.g. DN 50.

Where outlet and grating sizes are different, the nominal size shall be designated by the size of the grating then followed by the outlet connection end, e.g. DN 80 × DN 50.

8.3 Waterway

The minimum waterway shall be —

- a) not less than the area specified in Table 1; or
- b) capable of discharging a flow rate greater than the maximum flow rate from a tap outlet specified in the PCA, when tested in accordance with EN 274.2.

NOTE: The maximum flow rates for cold and heated water outlets are specified by the PCA.

TABLE 1

Nominal Size (DN)	Minimum waterway area (mm ²)
32	250
40	450
50	800
65	800
80	800
90	1000
100	1200
150	2000

8.4 Grating

8.4.1 Grating Apertures

The grating may be the manufacturer's own design except that circular holes and regular polygon shapes with more than eight sides, which may pose a risk of finger entrapment, are not permitted.

8.4.2 Bath waste outlets

Bath waste outlet gratings shall be removable, without rotation of more than 90°, by the use of tools.

8.4.3 Grating surround

For waste outlets that are designed to be built in (e.g., tiled), the top of the body shall incorporate a surround to locate a removable grating. The surround shall be finished to at least the same height as the top of the grating, and shall be integral or permanently attached to the body of the waste outlet.

8.5 Waste outlet bodies

8.5.1 Fixture waste outlets

The dimensions of fixture waste outlets shall be in accordance with Figure 1 or to manufacturer's own design.

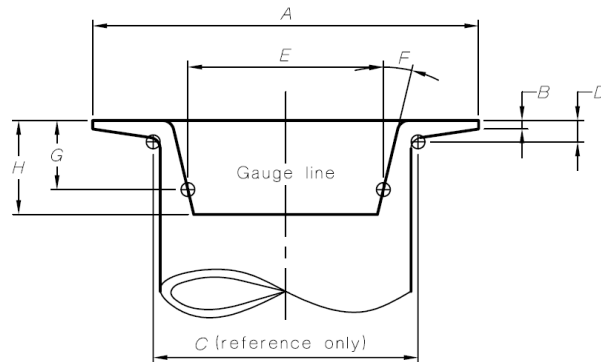

FIGURE 1 FIXTURE WASTE OUTLET DIMENSIONS

TABLE 2

Nominal size or type	A*	B		C (Ref. only) (max.)	D (max.)	E†	F‡	G (reference only)	H (min.)
		mm	mm						
DN	mm	min.	max.	mm	mm	mm	degrees	mm	mm
32	66.5	0.5	1.8	46.0	3.5	33.3	14	12.0	12.0
40	66.5	0.5	1.8	52.0	3.5	41.3	14	12.0	12.0
50	87.0	0.5	1.8	65.0	3.5	50.8	14	12.0	15.0
65	99.7	0.5	1.8	—	—	—	—	—	—
80	101.3	0.5	1.8	—	—	—	—	—	—
100	126.7	0.5	1.8	—	—	—	—	—	—
150	177.5	0.5	1.8	—	—	—	—	—	—
Flange to suit sink outlet waste disposal unit	113.5	0.9	1.8	90.0	3.5	—	—	—	—
Alternative flange to suit shower base outlet	103.0	0.9	1.8	89.0	4.6	—	—	—	—

* Tolerance ± 1.5 mm.

† Tolerance ± 0.5 mm.

‡ Tolerance $\pm 1^\circ$

8.6 Connection ends

Dimensional compliance or compliance with relevant or corresponding Australian Standard for pipe or pipefitting.

- a) AS 1589 for metallic waste fittings.
- b) AS 2887 for plastics bodied waste fittings.

8.7 Freedom from defects

8.7.1 *General*

Defects shall not affect the performance, function or safe handling of the fitting in service.

8.7.2 *Plastics-bodied waste fittings*

Finished plastics waste fittings shall comply with the following:

- a) They shall be free from blisters or heat marks.
- b) They shall be free from chips and rough edges.
- c) Sharp edges shall be removed.
- d) Jointing edges shall taper uniformly from the mouth to the root.

8.7.3 *Metallic fittings*

Finished metallic waste fittings shall be—

- a) free from metal folds, laps, laminations and blowholes that would affect the performance of the fitting in service;
- b) free from pits on jointing surfaces;
- c) clean and free of sand and swarf; and
- d) free from burrs, fins and sharp edges.

9 PERFORMANCE REQUIREMENTS AND TEST METHODS

9.1 Load test

9.1.1 Waste outlets intended for bathroom (barefoot) applications and subject to live loads, shall comply with the Load Test requirements of:

- a) AS 1589 for metallic waste fittings; or
- b) AS 2887 for plastics bodied waste fittings; or
- c) EN 1253-1.

9.1.2 Where intended for use in vehicular or pedestrian areas (non-barefoot areas), products shall comply with AS 3996.

9.2 Plastics thread tightening torque test

When tested in accordance with AS 2888.1, the threaded component shall be capable of being tightened without damage when a torque, as specified in AS 2887, is applied.

9.3 Thermal cycling test

When tested in accordance with AS 2888.8 with components tightened to a torque of 10 Nm +2 –0 Nm, the fitting shall not crack or permanently distort and the surface finish shall not split, flake or peel.

9.4 Seal test

For waste outlets that incorporate an integral plug system, when tested in accordance with AS 2888.7, the plug system shall withstand a hydrostatic head of 1.00 +0.01 –0.00 m for 5 +5 –0 min without leaking or becoming inoperable.

10 PERFORMANCE TEST SEQUENCE

VOID

11 PRODUCT DOCUMENTATION

11.1 Product data

Product data that identifies critical product characteristics and limitations, such as the following, shall be available:

- a) Maximum live load bearing.

- b) Jointing methods and adaptation to other piping systems.
- c) Product range and model identification.

11.2 Installation instructions

Installation instructions shall be provided that include:

- a) Reference to installation in accordance with the Plumbing Code of Australia, including any limitations on the product's use.

NOTE:- A material or product that is listed on the WaterMark Product Database and is marked in accordance with the WaterMark Certification Scheme is recognised by authorities having jurisdiction as being authorised for use in a plumbing or drainage installation. This is because the material or product complies with the applicable product specification. The installation of an authorised material or product must meet the requirements of the PCA. Where the installation does not comply with the PCA installation requirements, or where the PCA does not contain installation requirements applicable to the authorised material or product, acceptance of the installation is at the discretion of the authority having jurisdiction.

- b) Detailed step-by-step instruction.
- c) Where applicable:
 - a) Reference to the need for special tools or training.
 - b) Commissioning procedures and adjustments required.
 - c) Troubleshooting guide.
- d) Contact details for after-sales service.

Appendix A MEANS FOR DEMONSTRATING COMPLIANCE WITH THIS TECHNICAL SPECIFICATION

(Normative)

A.1 SCOPE

This Appendix sets out the means by which compliance with this Technical Specification is to be demonstrated by a manufacturer under the WaterMark Certification Scheme.

A.2 RELEVANCE

The long-term performance of plumbing systems is critical to the durability of building infrastructure, protection of public health and safety, and protection of the environment.

A.3 PRODUCT CERTIFICATION

The purpose of product certification is to provide independent assurance of the claim by the manufacturer that products comply with this Technical Specification.

The sampling and testing plan, as detailed in Paragraph A5 and Table A1, shall be used by the WaterMark Conformity Assessment Body. Where a batch release testing program is required, it shall be carried out by the manufacturer as detailed in Paragraph A5 and Table A2.

A.4 DEFINITIONS

A.4.1 Batch release test

A test performed by the manufacturer on a batch of components, which has to be satisfactorily completed before the batch can be released.

A.4.2 Production batch

Clearly identifiable collection of units, manufactured consecutively or continuously under the same conditions, using material or compound to the same specification.

A.4.3 Sample

One or more units of product drawn from a batch, selected at random without regard to quality.

NOTE: The number of units of product in the sample is the sample size.

A.4.4 Sampling plan

A specific plan that indicates the number of units of components or assemblies to be inspected.

A.4.5 Type test batch

Schedule of units of the same type, identical dimensional characteristics, all the same nominal diameter and wall thickness, from the same compound. The batch is defined by the manufacturer.

A.4.6 Type testing

Testing performed to demonstrate that the material, component, joint or assembly is capable of conforming to the requirements given in the Technical Specification.

A.5 TESTING

A.5.1 Type testing

Table A1 sets out the requirements for type testing and frequency of re-verification.

A.5.2 Batch release testing

Table A2 sets out the minimum sampling and testing frequency plan for a manufacturer to demonstrate compliance of product(s) to this Technical Specification on an ongoing basis. However, where the manufacturer can demonstrate adequate process control to the WaterMark Conformity Assessment Body, the frequency of the sampling and testing nominated by the manufacturer's quality plan and/or documented procedures shall take precedence for the purposes of WaterMark product certification.

A.5.3 Retesting

In the event of a test failure, the products within the batch shall be tested at an appropriate acceptable quality level (AQL) and only those batches found to comply may be claimed and/or marked as complying with this Technical Specification.



Table A1—TYPE TESTS

Characteristic	Clause	Requirement	Test method	Frequency
Materials	5.1	Materials and corrosion resistance	Clause 5.1	On change of material
Design	8.3	Waterway	Clause 8.3 and EN 274-2	On change of design
	8.4	Grating	Clause 8.4	
	8.5	Waste outlet bodies	Clause 8.5	
	8.6	Connection ends	AS 1589 and AS 2887	
Performance	9.1	Load test	Clause 9.1	On change of design
	9.2	Thread tightening torque (for plastics products)	AS 2888.1	On change of design of connection end
	9.3	Thermal cycling	AS 2888.8	On change of material
	9.4	Seal test	AS 2888.7	On change of design

Table A2—BATCH RELEASE TESTS

Characteristic	Clause	Requirement	Test method	Frequency
Materials	5.1	Materials and corrosion resistance	Clause 5.1	Once per batch
Design	8.6	Connection ends	AS 1589 and AS 2887	Once per batch
	8.7	Freedom from defects	Clause 8.7	100%